

---

# TAFS, TAFM, TAFL

---

BROCAS CON PLACAS INTERCAMBIABLES  
BAJO NIVEL DE RUIDO AL TALADRAR Y CUERPO  
RESISTENTE

---



*M*plus...

# TAFS, TAFM, TAFL

## BROCAS CON PLACAS INTERCAMBIABLES

### CARACTERÍSTICAS

#### Cuerpo resistente

- Y más amplio diseño de red reduce la vibración.
- Ahora menor ruido en el corte.
- Alta rigidez del asiento de la placa, para una fijación más fiable.

#### Placa económica

- Uso económico de los cuatro filos

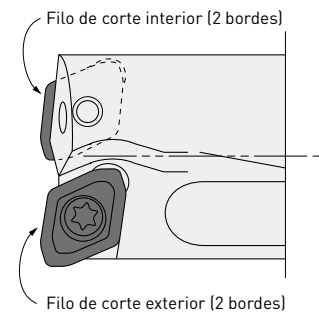
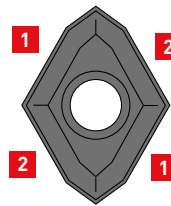
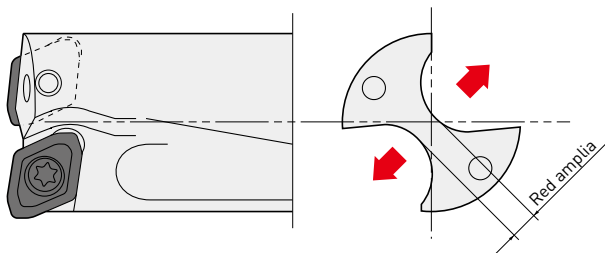

1 Filo interior

2 Filo exterior



# TAFS, TAFM, TAFL

## PRUEBAS DE CORTE

### GEOMETRÍA VIRUTA

#### Rompevirutas U1

Material	Acero dulce
Diámetro de la broca (mm)	Ø 25
Vc (m/min)	200
f (mm/rev.)	0.10



#### Rompevirutas U2

Material	DIN X5CrNi189
Diámetro de la broca (mm)	Ø 25
Vc (m/min)	150
f (mm/rev.)	0.10



#### Rompevirutas U3

Material	DIN Ck45
Diámetro de la broca (mm)	Ø 25
Vc (m/min)	150
f (mm/rev.)	0.14



#### Rompevirutas U3

Material	DIN 42CrMo4
Diámetro de la broca (mm)	Ø 25
Vc (m/min)	150
f (mm/rev.)	0.12



## RESISTENCIA DE CORTE

### CONSUMO DE POTENCIA

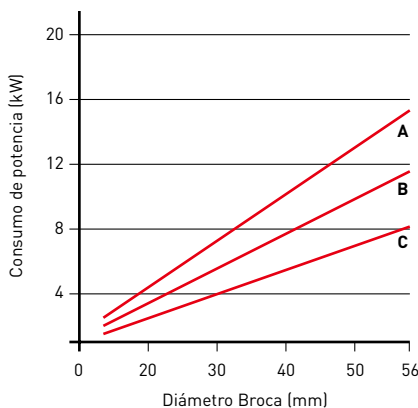

### TORSIÓN

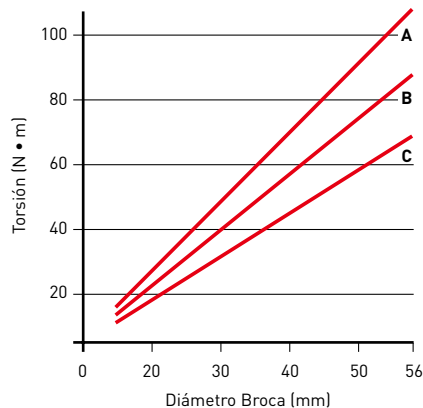

### FUERZA DE EMPUJE

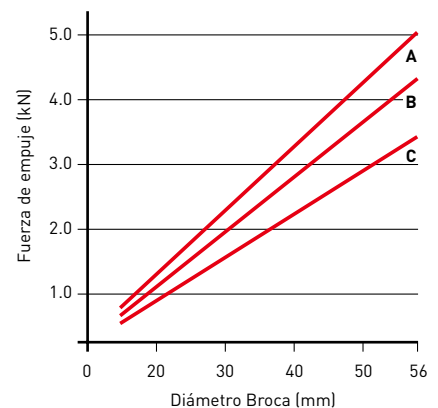

1. Material: DIN X5CrNi189 [220HB] Velocidad de corte: 150 m/min Placa: Rompevirutas U2

A: f = 0.15 mm/rev. B: f = 0.1 mm/rev. C: f = 0.06 mm/rev.

# TAFS, TAFM, TAFL

## RUIDO EN EL CORTE

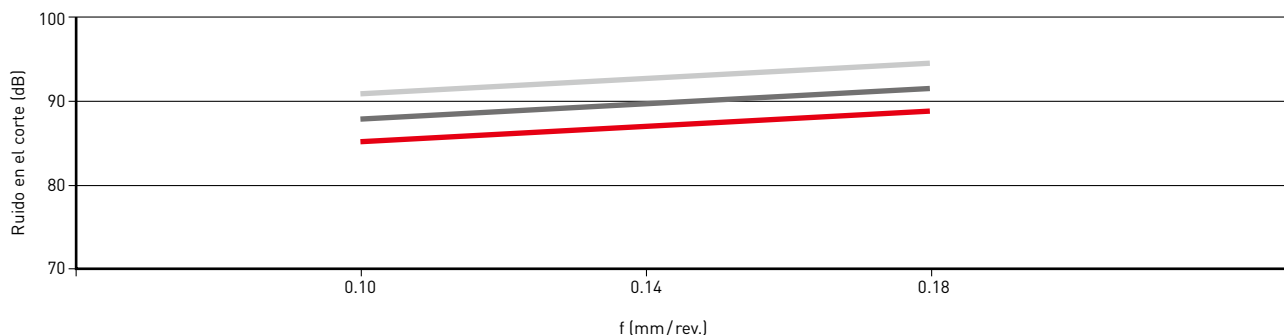

1. Material: DIN 42CrMo4 (200-220 HB) Diámetro Broca (mm): Ø 25 Velocidad de corte: 150 m/min Placa: Rompevirutas U2

## RESISTENCIA DE CORTE

### CONSUMO DE POTENCIA

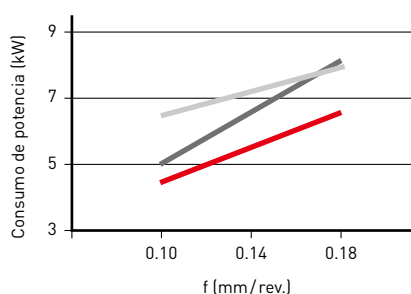

### TORSIÓN

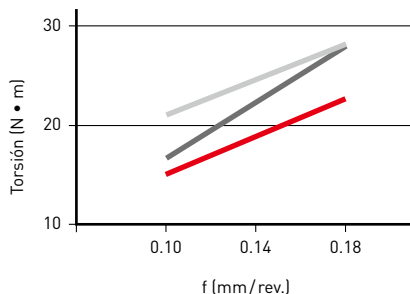

### FUERZA DE EMPUJE

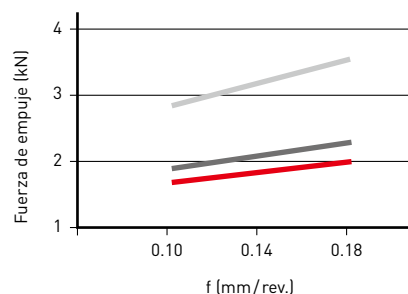

1. Material: DIN 42CrMo4 (200-220 HB) Diámetro Broca (mm): Ø 25 Velocidad de corte: 150 m/min Placa: Rompevirutas U3

## IDENTIFICACIÓN

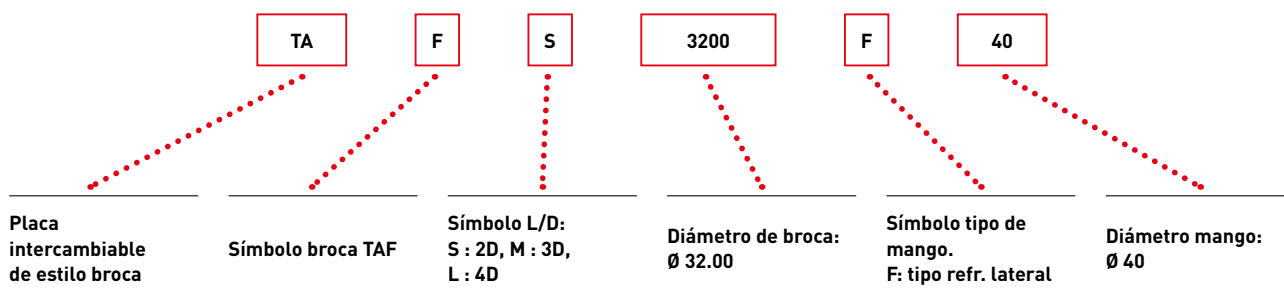

# TAFS, TAFM, TAFL

P M K

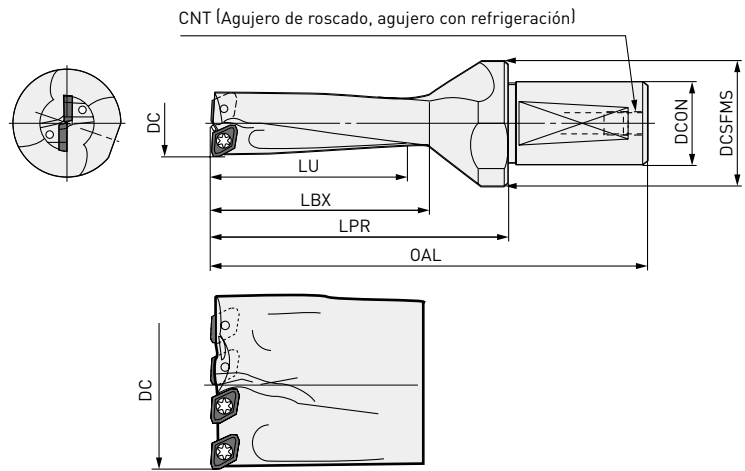

Número de dientes = 4 (DC > 49)

Referencia	Stock	DC	L/D	ZNF	LU	LBX	LPR	OAL	DCON	DCSFMS	CNT	Placa
TAFS1200F20	●		2		24	29	39	82	20	25	PT1/8	
TAFM1200F20	●	12.0	3	2	36	41	51	94	20	25	PT1/8	GCMT040204-U $\odot$
TAFL1200F20	●		4		48	53	63	106	20	25	PT1/8	
TAFS1250F20	●		2		25	29	39	82	20	25	PT1/8	
TAFM1250F20	●	12.5	3	2	37.5	41	51	94	20	25	PT1/8	GCMT040204-U $\odot$
TAFL1250F20	●		4		50	53	63	106	20	25	PT1/8	
TAFS1300F20	●		2		26	31	41	84	20	25	PT1/8	
TAFM1300F20	●	13.0	3	2	39	44	54	97	20	25	PT1/8	GCMT040204-U $\odot$
TAFL1300F20	●		4		52	57	67	110	20	25	PT1/8	
TAFS1350F20	●		2		27	31	41	84	20	25	PT1/8	
TAFM1350F20	●	13.5	3	2	40.5	44	54	97	20	25	PT1/8	GCMT040204-U $\odot$
TAFL1350F20	●		4		54	57	67	110	20	25	PT1/8	
TAFS1400F20	●		2		28	33	43	86	20	25	PT1/8	
TAFM1400F20	●	14.0	3	2	42	47	57	100	20	25	PT1/8	GCMT040204-U $\odot$
TAFL1400F20	●		4		56	61	71	114	20	25	PT1/8	
TAFS1450F20	●		2		29	33	43	86	20	25	PT1/8	
TAFM1450F20	●	14.5	3	2	43.5	47	57	100	20	25	PT1/8	GCMT040204-U $\odot$
TAFL1450F20	●		4		58	61	71	114	20	25	PT1/8	
TAFS1500F20	●		2		30	35	45	88	20	25	PT1/8	
TAFM1500F20	●	15.0	3	2	45	50	60	103	20	25	PT1/8	GPMT060204-U $\odot$
TAFL1500F20	●		4		60	65	75	118	20	25	PT1/8	
TAFS1550F20	●		2		31	35	45	88	20	25	PT1/8	
TAFM1550F20	●	15.5	3	2	46.5	50	60	103	20	25	PT1/8	GPMT060204-U $\odot$
TAFL1550F20	●		4		62	65	75	118	20	25	PT1/8	
TAFS1600F25	●		2		32	38	57	107	25	35	PT1/8	
TAFM1600F25	●	16.0	3	2	48	54	73	123	25	35	PT1/8	GPMT060204-U $\odot$
TAFL1600F25	●		4		64	70	89	139	25	35	PT1/8	
TAFS1650F25	●		2		33	38	57	107	25	35	PT1/8	
TAFM1650F25	●	16.5	3	2	49.5	54	73	123	25	35	PT1/8	GPMT060204-U $\odot$

# TAFS, TAFM, TAFL

Referencia	Stock	DC	L/D	ZNF	LU	LBX	LPR	OAL	DCON	DCSFMX	CNT	Placa
TAFS1700F25	●		2		34	41	59	109	25	35	PT1/8	GPMT060204-U○
TAFM1700F25	●	17.0	3	2	51	58	76	126	25	35	PT1/8	
TAFL1700F25	●		4		68	75	93	143	25	35	PT1/8	
TAFS1750F25	●		2		35	41	59	109	25	35	PT1/8	GPMT060204-U○
TAFM1750F25	●	17.5	3	2	52.5	58	76	126	25	35	PT1/8	
TAFL1750F25	●		4		70	75	93	143	25	35	PT1/8	
TAFS1800F25	●		2		36	43	61	111	25	35	PT1/8	GPMT070204-U○
TAFM1800F25	●	18.0	3	2	54	61	79	129	25	35	PT1/8	
TAFL1800F25	●		4		72	79	97	147	25	35	PT1/8	
TAFS1850F25	●		2		37	43	61	111	25	35	PT1/8	GPMT070204-U○
TAFM1850F25	●	18.5	3	2	55.5	61	79	129	25	35	PT1/8	
TAFL1850F25	●		4		74	80	98	146	25	35	PT1/8	
TAFS1900F25	●		2		38	46	63	113	25	35	PT1/8	GPMT070204-U○
TAFM1900F25	●	19.0	3	2	57	65	82	132	25	35	PT1/8	
TAFL1900F25	●		4		76	84	101	151	25	35	PT1/8	
TAFS1950F25	●		2		39	46	63	113	25	35	PT1/8	GPMT070204-U○
TAFM1950F25	●	19.5	3	2	58.5	65	82	132	25	35	PT1/8	
TAFL1950F25	●		4		77	84	101	151	25	35	PT1/8	
TAFS2000F25	●		2		40	48	65	115	25	35	PT1/8	GPMT070204-U○
TAFM2000F25	●	20.0	3	2	60	68	85	135	25	35	PT1/8	
TAFL2000F25	●		4		80	88	105	155	25	35	PT1/8	
TAFS2050F25	●		2		41	48	65	115	25	35	PT1/8	GPMT070204-U○
TAFM2050F25	●	20.5	3	2	61.5	68	85	135	25	35	PT1/8	
TAFL2050F25	●		4		81	88	105	155	25	35	PT1/8	
TAFS2100F25	●		2		42	50	67	117	25	35	PT1/8	GPMT070204-U○
TAFM2100F25	●	21.0	3	2	63	71	88	138	25	35	PT1/8	
TAFL2100F25	●		4		84	92	109	159	25	35	PT1/8	
TAFS2150F25	●		2		43	50	67	117	25	35	PT1/8	GPMT070204-U○
TAFM2150F25	●	21.5	3	2	64.5	71	88	138	25	35	PT1/8	
TAFL2150F25	●		4		85	92	109	159	25	35	PT1/8	
TAFS2200F25	●		2		44	53	69	119	25	35	PT1/8	GPMT070204-U○
TAFM2200F25	●	22.0	3	2	66	75	91	141	25	35	PT1/8	
TAFL2200F25	●		4		88	97	113	163	25	35	PT1/8	
TAFS2250F25	●		2		45	53	69	119	25	35	PT1/8	GPMT070204-U○
TAFM2250F25	●	22.5	3	2	67.5	75	91	141	25	35	PT1/8	
TAFL2250F25	●		4		89	97	113	163	25	35	PT1/8	
TAFS2300F25	●		2		46	55	71	121	25	35	PT1/8	GPMT090304-U○
TAFM2300F25	●	23.0	3	2	69	78	94	144	25	35	PT1/8	
TAFL2300F25	●		4		92	101	117	167	25	35	PT1/8	
TAFS2350F25	●		2		47	55	71	121	25	35	PT1/8	GPMT090304-U○
TAFM2350F25	●	23.5	3	2	70.5	78	94	144	25	35	PT1/8	
TAFL2350F25	●		4		94	101	117	167	25	35	PT1/8	
TAFS2400F25	●		2		48	58	73	123	25	35	PT1/8	GPMT090304-U○
TAFM2400F25	●	24.0	3	2	72	82	97	147	25	35	PT1/8	
TAFL2400F25	●		4		96	106	121	171	25	35	PT1/8	
TAFS2450F25	●		2		49	58	73	123	25	35	PT1/8	GPMT090304-U○
TAFM2450F25	●	24.5	3	2	73.5	82	97	147	25	35	PT1/8	
TAFL2450F25	●		4		97	106	121	171	25	35	PT1/8	
TAFS2500F32	●		2		50	60	75	130	32	42	PT1/8	GPMT090304-U○
TAFM2500F32	●	25.0	3	2	75	85	100	155	32	42	PT1/8	
TAFL2500F25	●		4		100	110	125	180	25	35	PT1/8	
TAFL2500F32	●		4		100	110	125	180	32	42	PT1/8	
TAFS2550F32	●		2		51	60	75	130	32	42	PT1/8	GPMT090304-U○
TAFM2550F32	●	25.5	3	2	76.5	85	100	155	32	42	PT1/8	
TAFL2550F32	●		4		101	110	125	180	32	42	PT1/8	
TAFS2600F32	●		2		52	62	77	132	32	42	PT1/8	GPMT090304-U○
TAFM2600F32	●	26.0	3	2	78	88	103	158	32	42	PT1/8	
TAFL2600F32	●		4		104	114	129	184	32	42	PT1/8	

# TAFS, TAFM, TAFL

Referencia	Stock	DC	L/D	ZNF	LU	LBX	LPR	OAL	DCON	DCSFMX	CNT	Placa
TAFS2650F32	●		2		53	62	77	132	32	42	PT1/8	
TAFM2650F32	●	26.5	3	2	79.5	88	103	158	32	42	PT1/8	GPMT090304-U○
TAFL2650F32	●		4		106	114	129	184	32	42	PT1/8	
TAFS2700F32	●		2		54	65	79	134	32	42	PT1/8	
TAFM2700F32	●	27.0	3	2	81	92	106	161	32	42	PT1/8	GPMT090304-U○
TAFL2700F32	●		4		108	119	133	188	32	42	PT1/8	
TAFS2750F32	●		2		55	65	79	134	32	42	PT1/8	
TAFM2750F32	●	27.5	3	2	82.5	92	106	161	32	42	PT1/8	GPMT090304-U○
TAFS2800F32	●		2		56	67	81	136	32	42	PT1/8	
TAFM2800F32	●	28.0	3	2	84	95	109	164	32	42	PT1/8	GPMT11T308-U○
TAFL2800F32	●		4		112	123	137	192	32	42	PT1/8	
TAFS2850F32	●		2		57	67	81	136	32	42	PT1/8	
TAFM2850F32	●	28.5	3	2	85.5	95	109	164	32	42	PT1/8	GPMT11T308-U○
TAFL2850F40	●		4		114	123	137	202	40	50	PT1/8	
TAFS2900F32	●		2		58	70	83	138	32	42	PT1/8	
TAFM2900F32	●	29.0	3	2	87	99	112	167	32	42	PT1/8	GPMT11T308-U○
TAFL2900F32	●		4		116	128	141	196	32	42	PT1/8	
TAFS2950F32	●		2		59	70	83	138	32	42	PT1/8	
TAFM2950F32	●	29.5	3	2	88.5	99	112	167	32	42	PT1/8	GPMT11T308-U○
TAFS3000F32	●		2		60	72	90	145	32	50	PT1/8	
TAFS3000F40	●		2		60	72	90	155	40	50	PT1/4	
TAFM3000F32	●	30.0	3	2	90	102	120	175	32	50	PT1/8	GPMT11T308-U○
TAFM3000F40	●		3		90	102	120	185	40	50	PT1/4	
TAFL3000F32	●		4		120	132	150	205	32	42	PT1/8	
TAFL3000F40	●		4		120	132	150	215	40	50	PT1/4	
TAFS3050F40	●		2		61	72	90	155	40	50	PT1/4	
TAFM3050F40	●	30.5	3	2	91.5	102	120	185	40	50	PT1/4	GPMT11T308-U○
TAFS3100F32	●		2		62	74	92	147	32	50	PT1/8	
TAFS3100F40	●		2		62	74	92	157	40	50	PT1/4	
TAFM3100F32	●	31.0	3	2	93	105	123	178	32	50	PT1/8	GPMT11T308-U○
TAFM3100F40	●		3		93	105	123	188	40	50	PT1/4	
TAFL3100F32	●		4		124	135	154	209	32	42	PT1/8	
TAFL3100F40	●		4		124	136	154	219	40	50	PT1/4	
TAFS3200F32	●		2		64	77	94	149	32	50	PT1/8	
TAFS3200F40	●		2		64	77	94	159	40	50	PT1/4	
TAFM3200F32	●	32.0	3	2	96	109	126	181	32	50	PT1/8	GPMT11T308-U○
TAFM3200F40	●		3		96	109	126	191	40	50	PT1/4	
TAFL3200F32	●		4		128	141	158	213	32	42	PT1/8	
TAFL3200F40	●		4		128	141	158	223	40	50	PT1/4	
TAFS3300F32	●		2		66	79	96	151	32	50	PT1/8	
TAFS3300F40	●		2		66	79	96	161	40	50	PT1/4	
TAFM3300F32	●	33.0	3	2	99	112	129	184	32	50	PT1/8	GPMT11T308-U○
TAFM3300F40	●		3		99	112	129	194	40	50	PT1/4	
TAFL3300F32	●		4		132	145	162	217	32	42	PT1/8	
TAFL3300F40	●		4		132	145	162	227	40	50	PT1/4	
TAFS3400F32	●		2		68	82	98	153	32	50	PT1/8	
TAFS3400F40	●		2		68	82	98	163	40	50	PT1/4	
TAFM3400F32	●	34.0	3	2	102	116	132	187	32	50	PT1/8	GPMT11T308-U○
TAFM3400F40	●		3		102	116	132	197	40	50	PT1/4	
TAFL3400F32	●		4		136	150	166	231	32	42	PT1/8	
TAFL3400F40	●		4		136	150	166	231	40	50	PT1/4	

# TAFS, TAFM, TAFL

Referencia	Stock	DC	L/D	ZNF	LU	LBX	LPR	OAL	DCON	DCSFMX	CNT	Placa
TAFS3500F32	●		2		70	84	100	155	32	50	PT1/8	GPMT140408-U○
TAFS3500F40	●		2		70	84	100	165	40	50	PT1/4	
TAFM3500F32	●	35.0	3	2	105	119	135	190	32	50	PT1/8	
TAFM3500F40	●		3		105	119	135	200	40	50	PT1/4	
TAF3500F32	●		4		140	154	170	235	32	42	PT1/8	
TAF3500F40	●		4		140	154	170	235	40	50	PT1/4	
TAFS3600F32	□		2		72	86	102	157	32	50	PT1/8	GPMT140408-U○
TAFS3600F40	□		2		72	86	102	167	40	50	PT1/4	
TAFM3600F32	□	36.0	3	2	108	122	138	193	32	50	PT1/8	
TAFM3600F40	□		3		108	122	138	203	40	50	PT1/4	
TAF3600F32	□		4		144	158	174	229	32	42	PT1/8	
TAF3600F40	□		4		144	158	174	239	40	50	PT1/4	
TAFS3700F32	□		2		74	89	104	159	32	50	PT1/8	GPMT140408-U○
TAFS3700F40	□		2		74	89	104	169	40	50	PT1/4	
TAFM3700F32	□	37.0	3	2	111	126	141	196	32	50	PT1/8	
TAFM3700F40	□		3		111	126	141	206	40	50	PT1/4	
TAF3700F32	□		4		148	163	178	233	32	42	PT1/8	
TAF3700F40	□		4		148	163	178	243	40	50	PT1/4	
TAFS3750F32	□		2		75	89	104	159	32	50	PT1/8	GPMT140408-U○
TAFS3750F40	□		2		75	89	104	169	40	50	PT1/4	
TAFM3750F32	□	37.5	3	2	112.5	126	141	196	32	50	PT1/8	
TAFM3750F40	□		3		112.5	126	141	206	40	50	PT1/4	
TAF3750F32	□		4		150	163	178	233	32	42	PT1/8	
TAF3750F40	□		4		150	163	178	243	40	50	PT1/4	
TAFS3800F32	□		2		76	91	106	161	32	50	PT1/8	GPMT140408-U○
TAFS3800F40	□		2		76	91	106	171	40	50	PT1/4	
TAFM3800F32	□	38.0	3	2	114	129	144	199	32	50	PT1/8	
TAFM3800F40	□		3		114	129	144	209	40	50	PT1/4	
TAF3800F32	□		4		152	167	182	247	32	42	PT1/8	
TAF3800F40	□		4		152	167	182	247	40	50	PT1/4	
TAFS3900F32	□		2		78	94	108	163	32	50	PT1/8	GPMT140408-U○
TAFS3900F40	□		2		78	94	108	173	40	50	PT1/4	
TAFM3900F32	□	39.0	3	2	117	133	147	202	32	50	PT1/8	
TAFM3900F40	□		3		117	133	147	212	40	50	PT1/4	
TAF3900F32	□		4		156	172	186	251	32	42	PT1/8	
TAF3900F40	□		4		156	172	186	251	40	50	PT1/4	
TAFS4000F32	□		2		80	96	110	165	32	50	PT1/8	GPMT140408-U○
TAFS4000F40	□		2		80	96	110	175	40	50	PT1/4	
TAFM4000F32	□	40.0	3	2	120	136	150	205	32	50	PT1/8	
TAFM4000F40	□		3		120	136	150	215	40	50	PT1/4	
TAF34000F32	□		4		160	176	190	245	32	42	PT1/8	
TAF34000F40	□		4		160	176	190	255	40	50	PT1/4	
TAFS4100F40	□		2		82	98	112	177	40	50	PT1/4	GPMT140408-U○
TAFM4100F40	□	41.0	3	2	123	139	153	218	40	50	PT1/4	
TAF34100F40	□		4		164	180	194	259	40	50	PT1/4	
TAFS4200F40	□		2		84	101	114	179	40	50	PT1/4	GPMT140408-U○
TAFM4200F40	□	42.0	3	2	126	143	156	221	40	50	PT1/4	
TAF34200F40	□		4		168	185	198	263	40	50	PT1/4	
TAFS4300F40	□		2		86	103	116	181	40	50	PT1/4	GPMT140408-U○
TAFM4300F40	□	43.0	3	2	129	146	159	224	40	50	PT1/4	
TAF34300F40	□		4		172	189	202	267	40	50	PT1/4	



# TAFS, TAFM, TAFL

Referencia	Stock	DC	L/D	ZNF	LU	LBX	LPR	OAL	DCON	DCSFMX	CNT	Placa
TAFS4400F40	<input type="checkbox"/>		2		88	106	118	183	40	50	PT1/4	
TAFM4400F40	<input type="checkbox"/>	44.0	3	2	132	150	162	227	40	50	PT1/4	GPMT140408-U
TAFL4400F40	<input type="checkbox"/>		4		176	194	206	271	40	50	PT1/4	
TAFS4500F40	<input type="checkbox"/>		2		90	108	120	185	40	54	PT1/4	
TAFM4500F40	<input type="checkbox"/>	45.0	3	2	135	153	165	230	40	54	PT1/4	GPMT140408-U
TAFL4500F40	<input type="checkbox"/>		4		180	198	210	275	40	54	PT1/4	
TAFS4600F40	<input type="checkbox"/>		2		92	110	122	187	40	54	PT1/4	
TAFM4600F40	<input type="checkbox"/>	46.0	3	2	138	156	168	233	40	54	PT1/4	GPMT140408-U
TAFL4600F40	<input type="checkbox"/>		4		184	202	214	279	40	54	PT1/4	
TAFS4700F40	<input type="checkbox"/>		2		94	113	124	189	40	54	PT1/4	
TAFM4700F40	<input type="checkbox"/>	47.0	3	2	141	160	171	236	40	54	PT1/4	GPMT140408-U
TAFL4700F40	<input type="checkbox"/>		4		188	207	218	283	40	54	PT1/4	
TAFS4800F40	<input type="checkbox"/>		2		96	115	126	191	40	54	PT1/4	
TAFM4800F40	<input type="checkbox"/>	48.0	3	2	144	163	174	239	40	54	PT1/4	GPMT140408-U
TAFL4800F40	<input type="checkbox"/>		4		192	211	222	287	40	54	PT1/4	
TAFS4900F40	<input type="checkbox"/>		2		98	118	133	198	40	58	PT1/4	
TAFM4900F40	<input type="checkbox"/>	49.0	3	4	147	167	182	247	40	58	PT1/4	GPMT090304-U
TAFL4900F40	<input type="checkbox"/>		4		196	216	231	296	40	58	PT1/4	
TAFS5000F40	<input type="checkbox"/>		2		100	120	135	200	40	58	PT1/4	
TAFM5000F40	<input type="checkbox"/>	50.0	3	4	150	170	185	250	40	58	PT1/4	GPMT090304-U
TAFL5000F40	<input type="checkbox"/>		4		200	220	235	300	40	58	PT1/4	
TAFS5100F40	<input type="checkbox"/>		2		102	122	137	202	40	58	PT1/4	
TAFM5100F40	<input type="checkbox"/>	51.0	3	4	153	173	188	253	40	58	PT1/4	GPMT090304-U
TAFL5100F40	<input type="checkbox"/>		4		204	224	239	304	40	58	PT1/4	
TAFS5200F40	<input type="checkbox"/>		2		104	125	139	204	40	58	PT1/4	
TAFM5200F40	<input type="checkbox"/>	52.0	3	4	156	177	191	256	40	58	PT1/4	GPMT090304-U
TAFL5200F40	<input type="checkbox"/>		4		208	229	243	308	40	58	PT1/4	
TAFS5300F40	<input type="checkbox"/>		2		106	127	141	206	40	63	PT1/4	
TAFM5300F40	<input type="checkbox"/>	53.0	3	4	159	180	194	259	40	63	PT1/4	GPMT090304-U
TAFL5300F40	<input type="checkbox"/>		4		212	233	247	312	40	63	PT1/4	
TAFS5400F40	<input type="checkbox"/>		2		108	128	143	208	40	63	PT1/4	
TAFM5400F40	<input type="checkbox"/>	54.0	3	4	162	182	197	262	40	63	PT1/4	GPMT090304-U
TAFL5400F40	<input type="checkbox"/>		4		216	236	251	316	40	63	PT1/4	
TAFS5500F40	<input type="checkbox"/>		2		110	130	145	210	40	63	PT1/4	
TAFM5500F40	<input type="checkbox"/>	55.0	3	4	165	185	200	265	40	63	PT1/4	GPMT090304-U
TAFL5500F40	<input type="checkbox"/>		4		220	240	255	320	40	63	PT1/4	
TAFS5600F40	<input type="checkbox"/>		2		112	132	147	212	40	63	PT1/4	
TAFM5600F40	<input type="checkbox"/>	56.0	3	4	168	188	203	268	40	63	PT1/4	GPMT090304-U
TAFL5600F40	<input type="checkbox"/>		4		224	244	259	324	40	63	PT1/4	

# TAFS, TAFM, TAFL

## TIPO DE MAYOR RIGIDEZ

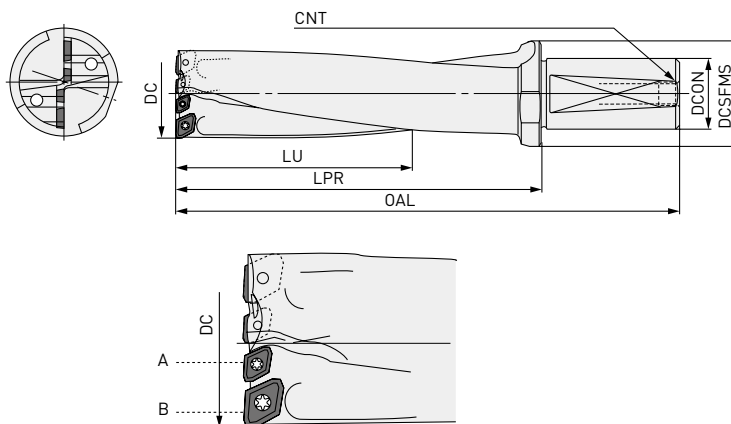

Referencia	Stock	DC	L/D	ZNF	DCON	DCSFMS	CNT	OAL	LPR	LU	Tipo interior/ exterior	Placa
TAFS5000F40-E	<input type="checkbox"/>		2	4	40	58	PT1/4	200	135	120	A	GPMT090304-U <sup>o</sup>
											B	GPMT11T308-U <sup>o</sup>
TAFM5000F40-E	<input type="checkbox"/>	50.0	3	4	40	58	PT1/4	250	185	170	A	GPMT090304-U <sup>o</sup>
											B	GPMT11T308-U <sup>o</sup>
TAFL5000F40-E	<input type="checkbox"/>		4	4	40	58	PT1/4	300	235	220	A	GPMT090304-U <sup>o</sup>
											B	GPMT11T308-U <sup>o</sup>
TAFS5100F40-E	<input type="checkbox"/>		2	4	40	58	PT1/4	202	137	122	A	GPMT090304-U <sup>o</sup>
											B	GPMT11T308-U <sup>o</sup>
TAFM5100F40-E	<input type="checkbox"/>	51.0	3	4	40	58	PT1/4	253	188	173	A	GPMT090304-U <sup>o</sup>
											B	GPMT11T308-U <sup>o</sup>
TAFL5100F40-E	<input type="checkbox"/>		4	4	40	58	PT1/4	304	239	224	A	GPMT090304-U <sup>o</sup>
											B	GPMT11T308-U <sup>o</sup>
TAFS5200F40-E	<input type="checkbox"/>		2	4	40	58	PT1/4	204	139	125	A	GPMT090304-U <sup>o</sup>
											B	GPMT11T308-U <sup>o</sup>
TAFM5200F40-E	<input type="checkbox"/>	52.0	3	4	40	58	PT1/4	256	191	177	A	GPMT090304-U <sup>o</sup>
											B	GPMT11T308-U <sup>o</sup>
TAFL5200F40-E	<input type="checkbox"/>		4	4	40	58	PT1/4	308	243	229	A	GPMT090304-U <sup>o</sup>
											B	GPMT11T308-U <sup>o</sup>
TAFS5300F40-E	<input type="checkbox"/>		2	4	40	63	PT1/4	206	141	127		
TAFM5300F40-E	<input type="checkbox"/>	53.0	3	4	40	63	PT1/4	259	194	180	A	GPMT11T308-U <sup>o</sup>
TAFL5300F40-E	<input type="checkbox"/>		4	4	40	63	PT1/4	312	247	233		
TAFS5400F40-E	<input type="checkbox"/>		2	4	40	63	PT1/4	208	134	128		
TAFM5400F40-E	<input type="checkbox"/>	54.0	3	4	40	63	PT1/4	262	197	182	A	GPMT11T308-U <sup>o</sup>
TAFL5400F40-E	<input type="checkbox"/>		4	4	40	63	PT1/4	316	251	236		
TAFS5500F40-E	<input type="checkbox"/>		2	4	40	63	PT1/4	210	145	130		
TAFM5500F40-E	<input type="checkbox"/>	55.0	3	4	40	63	PT1/4	265	200	185	A	GPMT11T308-U <sup>o</sup>
TAFL5500F40-E	<input type="checkbox"/>		4	4	40	63	PT1/4	320	255	240		
TAFS5600F40-E	<input type="checkbox"/>		2	4	40	63	PT1/4	212	147	132		
TAFM5600F40-E	<input type="checkbox"/>	56.0	3	4	40	63	PT1/4	268	203	188	A	GPMT11T308-U <sup>o</sup>
TAFL5600F40-E	<input type="checkbox"/>		4	4	40	63	PT1/4	324	259	244		

# TAFS, TAFM, TAFL

## PIEZAS DE REPUESTO

Tipo de portaherramientas

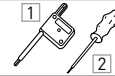

	Tornillo de fijación	Llave
GCMT040204-U○	TS2	1 TKY06F
GPMT060204-U○	TS2	1 TKY06F
GPMT070204-U○	TS25	1 TKY08F
GPMT090304-U○	TS3	1 TKY08F
GPMT11T308-U○	TS4	2 TKY15D
GPMT140408-U○	TS5	2 TKY25D
GPMT090304-U○	TS3	1 TKY08F

## PLACAS

Referencia	VP15TF	UP20M	GP20M	UE6020	US735	L	W1	IC	S	RE	Diám. broca	Forma
<b>U1</b>												
GCMT040204-U1	●					5.0	4.7	—	2.38	0.4	Ø 12 - 14.5	
GPMT060204-U1	●		●	●	—	—	—	5.56	2.38	0.4	Ø 15 - 17.5	
GPMT070204-U1	●		●	●	—	—	—	6.35	2.38	0.4	Ø 18 - 22.5	
GPMT090304-U1	●		●	●	—	—	—	7.94	3.18	0.4	Ø 23 - 27.5	
GPMT090304-U1	●		●	●	—	—	—	7.94	3.18	0.4	Ø 49 - 56	
GPMT11T308-U1	●		●	●	—	—	—	9.525	3.97	0.8	Ø 28 - 34	
GPMT140408-U1	●		●	●	—	—	—	12.70	4.76	0.8	Ø 35 - 48	
<b>U2</b>												
GCMT040204-U2	●	●				5.0	4.7	—	2.38	0.4	Ø 12 - 14.5	
GPMT060204-U2	●	●		●	●	—	—	5.56	2.38	0.4	Ø 15 - 17.5	
GPMT070204-U2	●	●		●	●	—	—	6.35	2.38	0.4	Ø 18 - 22.5	
GPMT090304-U2	●	●		●	●	—	—	7.94	3.18	0.4	Ø 23 - 27.5	
GPMT090304-U2	●	●		●	●	—	—	7.94	3.18	0.4	Ø 49 - 56	
GPMT11T308-U2	●	●		●	●	—	—	9.525	3.97	0.8	Ø 28 - 34	
GPMT140408-U2	●	●		●	●	—	—	12.70	4.76	0.8	Ø 35 - 48	
<b>U3</b>												
GPMT060204-U3	●		●	●	—	—	—	5.56	2.38	0.4	Ø 15 - 17.5	
GPMT070204-U3	●		●	●	—	—	—	6.35	2.38	0.4	Ø 18 - 22.5	
GPMT090304-U3	●		●	●	—	—	—	7.94	3.18	0.4	Ø 23 - 27.5	
GPMT090304-U3	●		●	●	—	—	—	7.94	3.18	0.4	Ø 49 - 56	
GPMT11T308-U3	●		●	●	—	—	—	9.525	3.97	0.8	Ø 28 - 34	
GPMT140408-U3	●		●	●	—	—	—	12.70	4.76	0.8	Ø 35 - 48	

# TAFS, TAFM, TAFL

## PLACA RECOMENDADA

### ROMPEVIRUTAS RECOMENDADO

Material	1.ª recomendación		2.ª recomendación	
	GCMT	GPMT	GCMT	GPMT
		U1	U1	
P Acero dulce			U2	U2
				U3
			U1	U1
				U2
Acero al carbono Acero aleado Acero para herramientas de aleación	U2	U2		U2
				U3
			U1	U1
M Acero inoxidable	U2	U2		
				U3
			U1	U1
K Fundición gris Fundición dúctil	U2	U3		U2

### RECOMENDACIÓN CALIDAD DE PLACA

Material	Calidad			
	1.ª recomendación		2.ª recomendación	
	GCMT	GPMT	GCMT	GPMT
P Acero dulce			VP15TF	VP15TF
	UP20M	UP20M		
			GP20M	
				UE6020
				US735
Acero al carbono Acero aleado Acero para herramientas de aleación	VP15TF	VP15TF		
			UP20M	UP20M
	GP20M	UE6020	GP20M	VP15TF
M Acero inoxidable				US735
	VP15TF	VP15TF		
	GP20M	US735	UP20M	UP20M
			GP20M	
K Fundición gris Fundición dúctil				UE6020
	VP15TF			
			UP20M	UP20M
	GP20M			UE6020
				US735
			VP15TF	

# TAFS, TAFM, TAFL

## CONDICIONES DE CORTE RECOMENDADAS

Material	Dureza	Vc				Vc					
		L/D = 2, 3		L/D = 4		Diám. broca					
		Ø 12 - Ø 14.5	Ø 15 -	Ø 16 -		Ø 12 - Ø 14.5	Ø 15 - Ø 22.5	Ø 23 - Ø 34	Ø 35 - Ø 48	Ø 49 - Ø 56	
P	Acero dulce	≤180HB	150 (100-200)	200 (150-300)	140 (100-200)	U1	0.06 (0.04-0.10)	0.07 (0.04-0.10)	0.08 (0.04-0.10)	0.10 (0.04-0.12)	0.08 (0.04-0.10)
						U2	0.06 (0.04-0.10)	0.08 (0.04-0.12)	0.10 (0.04-0.12)	0.12 (0.04-0.14)	0.10 (0.04-0.12)
						U3	—	0.08 (0.04-0.12)	0.10 (0.04-0.12)	0.12 (0.04-0.14)	0.10 (0.04-0.12)
	Acero al carbono	180-280 HB	120 (80-160)	150 (120-180)	100 (80-120)	U1	0.06 (0.04-0.10)	0.09 (0.06-0.12)	0.12 (0.08-0.14)	0.15 (0.08-0.18)	0.12 (0.08-0.14)
						U2	0.06 (0.04-0.10)	0.12 (0.06-0.14)	0.14 (0.08-0.18)	0.17 (0.08-0.20)	0.14 (0.08-0.18)
						U3	—	0.12 (0.06-0.14)	0.14 (0.08-0.18)	0.17 (0.08-0.20)	0.14 (0.08-0.18)
	Acero aleado	180-280 HB	120 (80-160)	150 (120-180)	100 (80-120)	U1	0.06 (0.04-0.10)	0.08 (0.06-0.10)	0.09 (0.06-0.12)	0.11 (0.06-0.14)	0.09 (0.06-0.12)
						U2	0.06 (0.04-0.10)	0.10 (0.06-0.12)	0.12 (0.08-0.16)	0.14 (0.08-0.18)	0.12 (0.08-0.16)
						U3	—	0.10 (0.06-0.12)	0.12 (0.08-0.16)	0.14 (0.08-0.18)	0.12 (0.08-0.16)
M	Acero inoxidable	≤200HB	100 (80-120)	150 (120-200)	110 (80-140)	U1	0.07 (0.04-0.10)	0.07 (0.04-0.10)	0.08 (0.04-0.10)	0.10 (0.04-0.12)	0.08 (0.04-0.10)
						U2	0.07 (0.04-0.10)	0.08 (0.04-0.12)	0.10 (0.04-0.14)	0.12 (0.04-0.16)	0.10 (0.04-0.14)
						U3	—	0.08 (0.04-0.12)	0.10 (0.04-0.14)	0.12 (0.04-0.16)	0.10 (0.04-0.14)
K	Fundición	Resistencia a la tracción ≤350MPa	120 (80-160)	150 (120-180)	140 (110-160)	U1	0.07 (0.06-0.10)	0.07 (0.06-0.10)	0.10 (0.04-0.14)	0.10 (0.06-0.14)	0.10 (0.06-0.14)
						U2	0.07 (0.06-0.10)	0.15 (0.10-0.18)	0.20 (0.10-0.25)	0.20 (0.10-0.25)	0.20 (0.10-0.25)
						U3	—	0.15 (0.10-0.18)	0.20 (0.10-0.25)	0.20 (0.10-0.25)	0.20 (0.10-0.25)
	Fundición dúctil	Resistencia a la tracción ≤450MPa	120 (80-150)	150 (120-180)	100 (80-120)	U1	0.06 (0.04-0.10)	0.07 (0.06-0.10)	0.10 (0.06-0.14)	0.10 (0.06-0.14)	0.10 (0.06-0.14)
						U2	0.06 (0.04-0.10)	0.12 (0.08-0.14)	0.15 (0.08-0.20)	0.18 (0.08-0.20)	0.15 (0.08-0.20)
						U3	—	0.12 (0.08-0.14)	0.15 (0.08-0.20)	0.18 (0.08-0.20)	0.15 (0.08-0.20)

1. Al utilizar brocas para l/d=4, el avance debería reducirse al 80 % de las recomendaciones previas.

# TAFS, TAFM, TAFL

## JUST FIT SLEEVE [JFS]

Un manguito para el vástago de la broca para permitir aumentar el diámetro de corte.

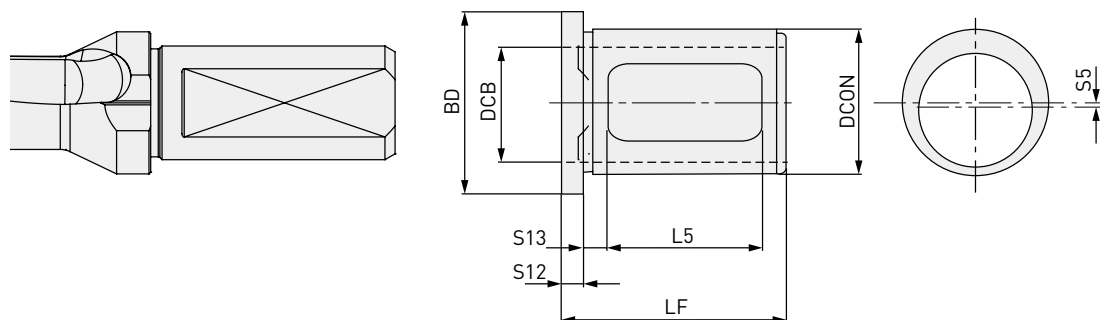

Referencia	Referencia kit	Stock	DCB	DCON	BD	LF	L5	* Aumento (S5×2)	Apta para: Brocas de tipo TAF
JFS2520-10	JFS-1	●	20	25	33	43	30	0.1	TAFS/M/L1200F20 - TAFS/M/L1550F20
JFS2520-20		●	20	25	33	43	30	0.2	
JFS2520-30		●	20	25	33	43	30	0.3	
JFS2520-40		●	20	25	33	43	30	0.4	
JFS2520-50		●	20	25	33	43	30	0.5	
JFS3225-10	JFS-2	●	25	32	40	50	34	0.1	TAFS/M/L1600F25 - TAFS/M/L2450F25
JFS3225-20		●	25	32	40	50	34	0.2	
JFS3225-30		●	25	32	40	50	34	0.3	
JFS3225-40		●	25	32	40	50	34	0.4	
JFS3225-50		●	25	32	40	50	34	0.5	
JFS4032-10	JFS-3	●	32	40	48	55	40	0.1	TAFS/M/L2500F32 - TAFS/M/L2950F32
JFS4032-20		●	32	40	48	55	40	0.2	
JFS4032-30		●	32	40	48	55	40	0.3	
JFS4032-40		●	32	40	48	55	40	0.4	
JFS4032-50		●	32	40	48	55	40	0.5	
JFS5040-10	JFS-4	●	40	50	68	65	50	0.1	AFS/M/L2850F40 - TAFS/M/L5600F40 TAFS/M/L5000F40-E
JFS5040-20		●	40	50	68	65	50	0.2	
JFS5040-30		●	40	50	68	65	50	0.3	
JFS5040-40		●	40	50	68	65	50	0.4	
JFS5040-50		●	40	50	68	65	50	0.5	

\* Aumento: Tamaño de aumento en el diámetro de corte.

# TAFS, TAFM, TAFL

## GUIA PARA ELEGIR JUST FIT SLEEVE

**Diámt. Deseado = Broca Ø + Incremento de JFS + 0.1 mm**

(Ej.) El diámetro deseado es 20.3 mm la tolerancia que tomamos es de 0.1 mm.

$$\text{Ø } 20.3 = (\text{TAFS/M/L2000F25} + \text{JFS3225-20}) + 0.1$$

Broca de 20 mm

Utilizando JFS un  
incremento de 0.2 mm

Voladizo

**Herramienta seleccionada**

Broca: TAFM2000F25

Just fit sleeve (JFS): JFS3225-20

1. La tolerancia puede variar debido a las condiciones de corte utilizadas, por favor siga la tabla de arriba.

## PEDIDOS DE JUST FIT SLEEVE

### MÉTODO DE COMPRA 1

El voladizo puede variar en función de las condiciones de corte utilizadas. Por lo tanto, se recomienda comprar como un lote. Cuando haga un pedido, utilice las referencias indicadas. (5 fundas/lote)

### MÉTODO DE COMPRA 2

Es posible hacer pedidos individualmente. Cuando haga un pedido, utilice las referencias individuales.

## APLICACIÓN DE JUST FIT SLEEVE

Cuando coloque la herramienta en el cono de amarre, alinee la ranura V con el filo periférico exterior de la broca, así como los agujeros redondos del eje periférico exterior de la brida del casquillo y los tornillos de amarre para fijar la broca. (Si la broca no tiene ranura V, alinear el rebaje del mango de la broca con los agujeros redondos del casquillo.)

Tornillos. A como brida lateral directamente para sujetar amarre de la broca. El tornillo B, solo aprieta a un grado para no dañar el cono.

- No se pueden realizar ajustes finos para el diámetro del casquillo.
- No puede utilizarse con herramientas con pinza de sujeción.

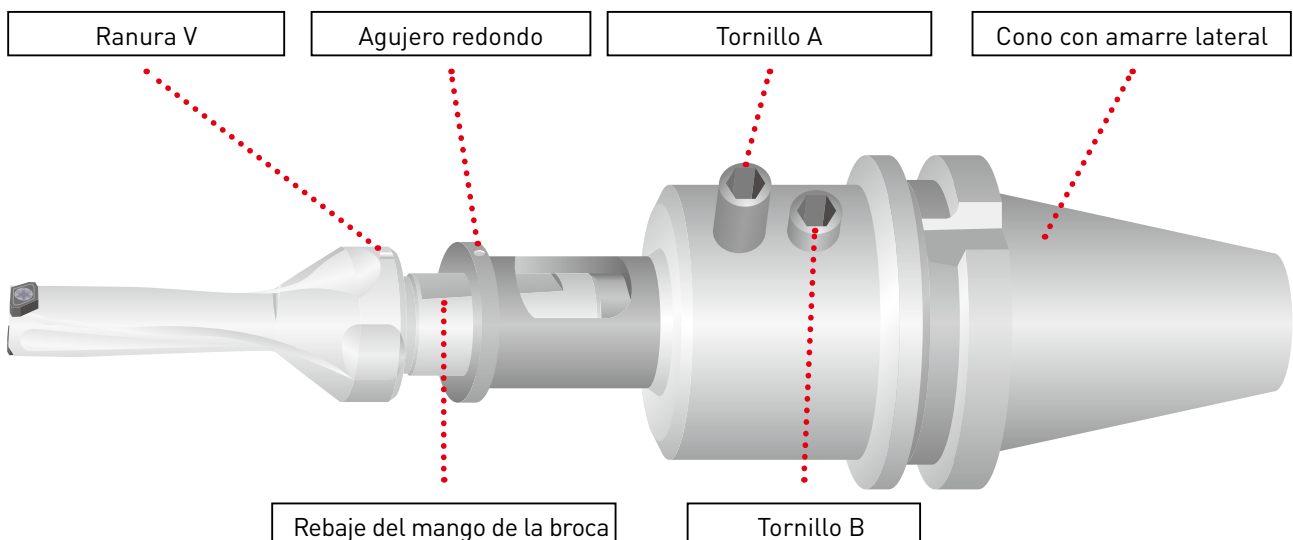

# TAFS, TAFM, TAFL

## EJEMPLOS DE APLICACIÓN

### TALADRADO DE CARAS ANGULADAS

Material	DIN 42CrMo4 (180 – 280 HB)
Herramienta	Ø 20 (3 x D)
Vc (m/min)	80
f (mm/rev.)	0.08

Herramienta	L (mm)	L (max.)
<b>TAF</b>	0.11	Bueno
Convencional A	0.17	Bueno
Convencional B	0.13	Los filos de corte interior y exterior se fracturan

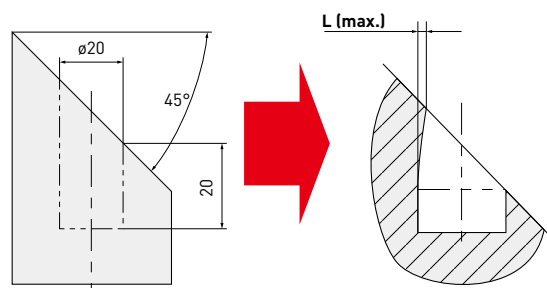

### TALADRADO DE PIEZAS REDONDAS

Material	DIN Ck50 (120 HB – 180 HB)
Herramienta	Ø 20 (3 x D)
Vc (m/min)	50, 80, 100
f (mm/rev.)	0.08 Corte inicial 0.05

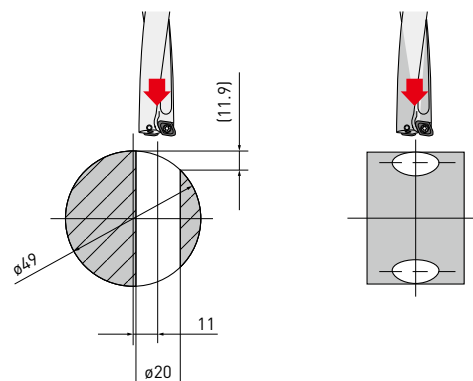

1. El filo de corte interior de la broca de la competencia se fractura.

### TALADRADO DE LADOS ABIERTOS

Material	DIN Ck50 (120 – 180 HB)
Herramienta	Ø 20 (3 x D)
Vc (m/min)	80
f (mm/rev.)	0.08

Sobremedida de la roca (con respecto al diámetro de broca medido)

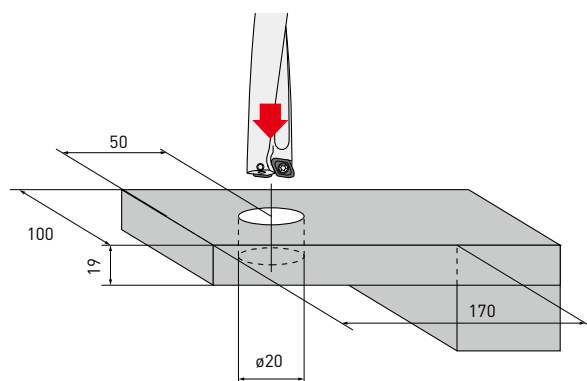
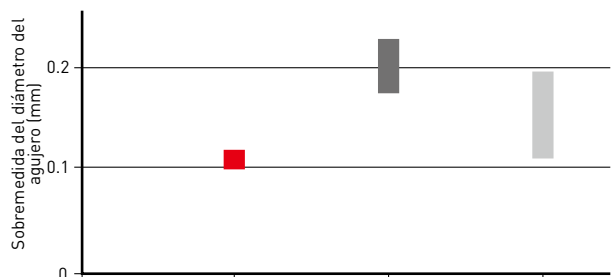



# TAFS, TAFM, TAFL

## APLICACIÓN

- Por favor, asegúrese que existe la máxima rigidez posible entre el eje de la máquina y el cono de amarre.
- Consulte la gráfica situada a la derecha para conocer el volumen y la presión de refrigeración. La refrigeración es un factor importante en la utilización eficaz de estas brocas.
- No se puede utilizar para taladrar planchas superpuestas.  
 En común con muchas brocas con placas intercambiables, estas producen unos discos que al no poder ser evacuados al mecanizar pueden producir roturas.

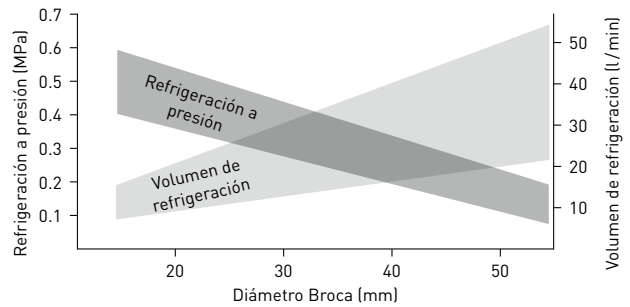

### UTILIZACIÓN EN UN TORNO

El filo de corte interior puede estar posicionado entre 0-0.2 mm sobre el centro.

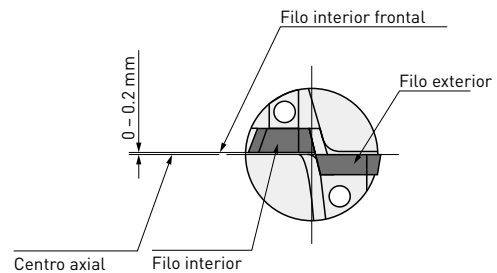

Para ajustar el diámetro del agujero con el desplazamiento de la broca, el filo de corte y el eje de la máquina deben estar en paralelo.

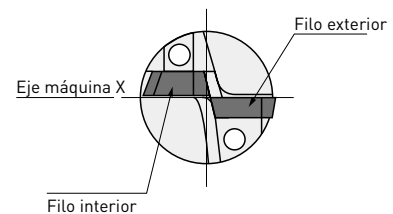

Cuando producimos un agujero de sobremedida. El desplazamiento no debe ser más del 2 % del diámetro. No es posible realizar agujeros más pequeños.

Cuando taladramos un agujero pasante en un torno, el disco producido al taladrar el material puede ser expulsado por la alta velocidad. Para reducir el peligro de daños ó deterioro es muy recomendable protegerlo con la cubierta.

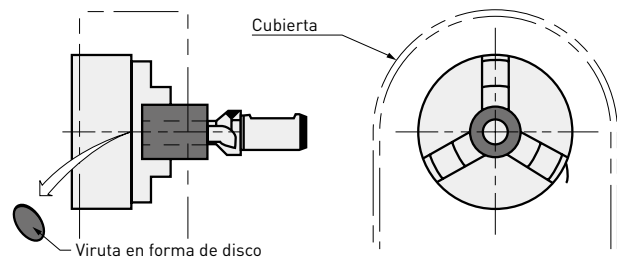







#### GERMANY

MMC HARTMETALL GMBH  
Comeniusstr. 2 . 40670 Meerbusch  
Phone +49 2159 91890 . Fax +49 2159 918966  
Email admin@mmchg.de

#### U.K.

MMC HARDMETAL U.K. LTD.  
Mitsubishi House . Galena Close . Tamworth . Staffs. B77 4AS  
Phone +44 1827 312312 . Fax +44 1827 312314  
Email sales@mitsubishicarbide.co.uk

#### SPAIN

MITSUBISHI MATERIALS ESPAÑA, S.A.  
Calle Emperador 2 . 46136 Museros/Valencia  
Phone +34 96 1441711 . Fax +34 96 1443786  
Email comercial@mmvalencia.es

#### FRANCE

MMC METAL FRANCE S.A.R.L.  
6, Rue Jacques Monod . 91400 Orsay  
Phone +33 1 69 35 53 53 . Fax +33 1 69 35 53 50  
Email mmfsales@mmc-metal-france.fr

#### POLAND

MMC HARDMETAL POLAND SP. Z O.O  
Al. Armii Krajowej 61 . 50-541 Wrocław  
Phone +48 71335 1620 . Fax +48 71335 1621  
Email sales@mitsubishicarbide.com.pl

#### RUSSIA

MMC HARDMETAL OOO LTD.  
Electrozavodskaya St. 24 . build. 3 . Moscow . 107023  
Phone +7 495 725 58 85 . Fax +7 495 981 39 79  
Email info@mmc-carbide.ru

#### ITALY

MMC ITALIA S.R.L.  
Viale Certosa 144 . 20156 Milano  
Phone +39 0293 77031 . Fax +39 0293 589093  
Email info@mmc-italia.it

#### TURKEY

MMC HARTMETALL GMBH ALMANYA - İZMİR MERKEZ ŞUBESİ  
Adalet Mahallesi Anadolu Caddesi No: 41-1 . 15001 35530 Bayraklı /İzmir  
Phone +90 232 5015000 . Fax +90 232 5015007  
Email info@mmchg.com.tr

[www.mitsubishicarbide.com](http://www.mitsubishicarbide.com) | [www.mmc-hardmetal.com](http://www.mmc-hardmetal.com)

DISTRIBUIDO POR:

┌

┐

└

┘

Referencia: MP110S | 

Publicado: 2022.04 (0). Impreso en Alemania